

CODOS 90° INOXIDABLE ALIMENTARIO PARA SOLDAR DIN 11852

STAINLESS STEEL WELDING BENDS 90° FOR FOOD INDUSTRIES DIN 11852

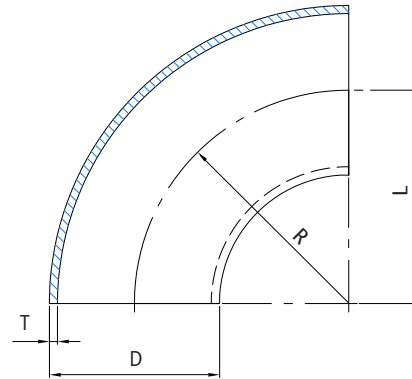

AISI 316L



CARACTERÍSTICAS BÁSICAS

- Fabricadas en acero inoxidable AISI 316L.
- Según norma DIN 11852.
- Acabado: Pulido.
- Terminación superficie: interna $Ra \leq 0,8 \mu\text{m}$.
- Unión de tubos acero inoxidable según DIN 11850 y UNE-EN 10357.

BASIC FEATURES

- Made of stainless steel AISI 316L.
- According to DIN 11852 standard.
- Ending: Polish.
- Internal surface finished $Ra \leq 0,8 \mu\text{m}$.
- Joining of stainless steel pipes according to DIN 11850 and EN 10357.

INFORMACIÓN TÉCNICA - TECHNICAL INFORMATION

Designación - Designation				DIMENSIONES - DIMENSIONS				Peso aprox. Weight aprox. (g)
COD.	Tubo de Acero Steel tube			Diámetro exterior Outside diameter D (mm)	Espesor Thickness T (mm)	Distancia Centro-Extremo Center-to-End Dimension L (mm)	Radio Radius R (mm)	
	DN	NPS	Ø ext (mm)					
IAC96010	10	3/8"	12	12,0 ± 0,1	1,5 ± 0,2	26 ± 2	26	15
IAC96015	15	1/2"	18	18,0 ± 0,1	1,5 ± 0,2	35 ± 2	35	30
IAC96020	20	3/4"	22	22,0 ± 0,1	1,5 ± 0,2	40 ± 2	40	45
IAC96025	25	1"	28	28,0 ± 0,2	1,5 ± 0,2	50 ± 2	50	70
IAC96032	32	1 1/4"	34	34,0 ± 0,2	1,5 ± 0,2	55 ± 2	55	90
IAC96040	40	1 1/2"	40	40,0 ± 0,2	1,5 ± 0,2	60 ± 2	60	125
IAC96050	50	2"	52	52,0 ± 0,3	1,5 ± 0,2	70 ± 2	70	200
IAC96065	65	2 1/2"	70	70,0 ± 0,4	2,0 ± 0,2	80 ± 2	80	385
IAC96080	80	3"	85	85,0 ± 0,4	2,0 ± 0,2	90 ± 2	90	545
IAC96100	100	4"	104	104,0 ± 0,8	2,0 ± 0,2	100 ± 2	100	790
IAC96125	125	5"	129	129,0 ± 1,0	2,0 ± 0,2	187,5 ± 2	187,5	1.900
IAC96150	150	6"	154	154,0 ± 1,2	2,0 ± 0,2	225 ± 2	225	2.720

Observaciones:

Dada la complejidad, variedad y gran cantidad de especificaciones particulares de cada instalación, en conjunción con la existencia de diversos factores que pueden afectar a las condiciones de trabajo y naturaleza del producto, es responsabilidad del usuario final realizar los ensayos necesarios para garantizar el correcto funcionamiento del producto en cada aplicación concreta. La instalación del producto deberá realizarse y mantenerse siguiendo códigos de buena práctica y/o estándares existentes.

Remarks:

Due to the complexity, variety and large number of particular specifications for each installation, along with the existence of diverse factors which can affect the working conditions and nature of the product, it is the responsibility of the end-user to carry out the necessary tests to ensure the proper functioning of the product in any specific application. Product installation must be carried out and maintained following the good practice codes and/or updated technical standards.

Nota : Debido al constante desarrollo de nuestros productos, los datos suministrados pueden ser alterados sin previo aviso.

Note : Due to the continuous development of our products, specifications may be changed without notification at any time.

Rev.1-06.20



Polígono Industrial ATUSA - Agurain S/N - 01200 Salvatierra (Alava) España
Tel.: (+34) 945 18 00 00 Fax : (+34) 945 30 01 53 e-mail: ventas@atusa.es
www.atusa.es

