

960

VANNE PAPILLON TYPE "LUG" LUG BUTTERFLY VALVES

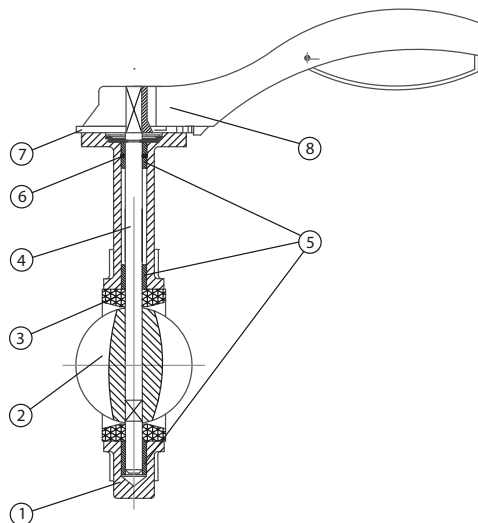

CE



DESCRIPTION DES COMPOSANTS - COMPONENTS DESCRIPTION

Ítem	Description - Description	Matière - Material
1	Corps - Body	Fonte ductile - Ductile Iron GGG 40 (EN-GJS-400-15)
2	Disque - Disc	Fonte ductile nickelée - Nickel Plated Ductile Iron GGG 40 (EN-GJS-400-15)
3	Siège - Seat	EPDM
4	Axe - Stem	Acier Inoxydable - Stainless Steel AISI 416
5	Paliers - Bushing	PTFE
6	Joints toriques - O-Ring	EPDM
7	Secteur cranté - Indicator Plate	Acier - Carbon Steel
8	Poignée - Hand Lever	Aluminium - Aluminium

CARACTERISTIQUES

- Pression de travail PN 16.
- Température de service : de - 10 °C à + 120 °C.
- Montage avec Brides PN 10/16.
- Revêtement extérieur poudre "EPOXY", 250 µm.
- Embase ISO 5211 pour le montage d'actionneur.
- Vanne de régulation.
- Axe en une seule pièce.
- Pas de crochet pour raccorder le disque et l'axe.
- Ne nécessite pas de joint pour un montage entre Brides.
- Design bidirectionnel.

DOMAINES D'APPLICATION

- Systèmes hydrauliques.
- Adduction d'eau et pompage.
- Applications industrielles basse pression et basse température.
- Installations d'irrigation.
- Ouvrages hydrauliques civiles.
- Climatisation.

BASIC FEATURES

- Working pressure PN 16.
- Working temperature: -10 °C to 120 °C.
- Suitable for flanges PN 10 / PN 16.
- Outside "EPOXY" powder coating, 250 µm.
- Top flange ISO 5211 for actuator.
- Control valve.
- One piece stem.
- Not pins to joint disc and stem.
- No need gaskets between valve and counter flanges.
- Bidirectional design.

GENERAL APPLICATIONS

- Water systems.
- Water supply, pumping and connection plants.
- Low pressure and low temperature industrial applications.
- Irrigation systems.
- Hydraulic and civil works.
- HVAC systems.

Rev.1-09.19
1/2



Polígono Industrial ATUSA - Agurain S/N - 01200 Salvatierra (Alava) España
Tel.: (+34) 945 18 00 00 Fax : (+34) 945 30 01 53 e-mail: ventas@atusa.es
www.atusa.es



960

VANNE PAPILLON TYPE "LUG" LUG BUTTERFLY VALVES

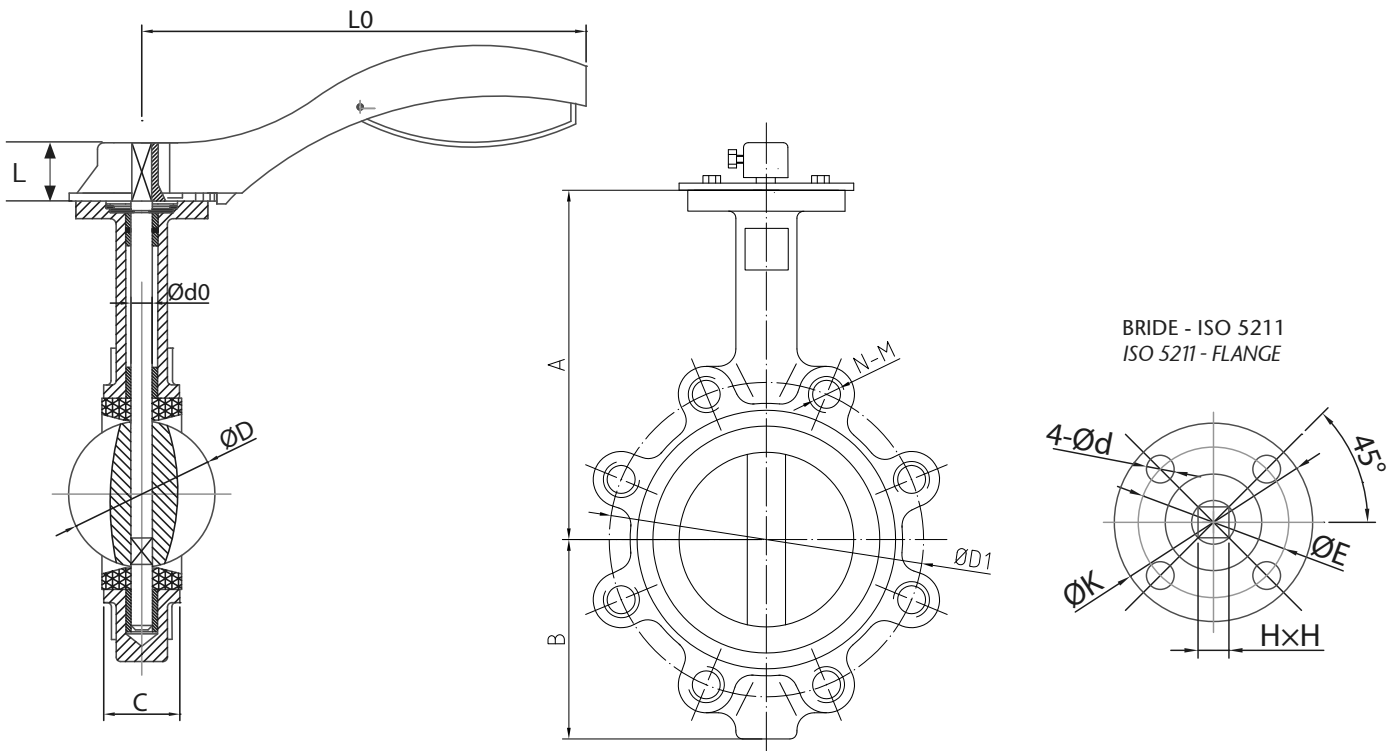

INFORMATION TECHNIQUE - TECHNICAL INFORMATION

DN	COD.	DIMENSIONS - DIMENSIONS (mm)														Poids approx. Weight approx. (Kg)	
		A	B	C	Ød0	ØD	L	L0	H x H	BRIDE/FLANGE			BRIDE/FLANGE - ISO 5211				
										PN	ØD1	N - M	4-Ød	K	E		
40	VF960040	142	72	33	11,0	41,8	23	170	9x9	10/16	110	4 - M16	F05	4 - 7	70	50	2,6
50	VF960050	130	67	42	12,6	52,9	23	170	9x9	10/16	125	4 - M16	F05	4 - 7	70	50	3,3
65	VF960065	140	71	45	12,6	64,5	23	170	9x9	10/16	145	4 - M16	F05	4 - 7	70	50	3,9
80	VF960080	148	91	46	12,6	78,8	24	170	11x11	10/16	160	8 - M16	F05	4 - 7	70	50	4,8
100	VF960100	164	99	52	15,8	104,0	24	170	11x11	10/16	180	8 - M16	F05	4 - 7	70	50	5,5
125	VF960125	213	127	55	18,9	123,3	27	220	14x14	10/16	210	8 - M16	F07	4 - 9	90	70	10,3
150	VF960150	226	139	56	18,9	155,1	27	220	14x14	10/16	240	8 - M20	F07	4 - 9	90	70	11,6
200	VF960201	260	175	61	22,1	202,5	30	260	17x17	10	295	8 - M20	F07	4 - 9	90	70	18,0
200	VF960200	260	175	61	22,1	202,5	30	260	17x17	16	295	12 - M20	F07	4 - 9	90	70	18,0
250	VF960251	292	203	66	28,5	250,5	31	350	22x22	10	350	12 - M20	F10	4 - 12	125	102	29,0
250	VF960250	292	203	66	28,5	250,5	31	350	22x22	16	355	12 - M24	F10	4 - 12	125	102	29,0
300	VF960301	337	242	77	31,6	301,6	31	350	22x22	10	400	12 - M20	F10	4 - 12	125	102	43,0
300	VF960300	337	242	77	31,6	301,6	31	350	22x22	16	410	12 - M24	F10	4 - 12	125	102	43,0

Note : En raison de l'évolution constante de nos produits, ces spécifications peuvent être modifiées sans préavis.

Note : Due to the continuous development of our products, specifications may be changed without notification at any time.

Rev.1-09.19

2/2



Polígono Industrial ATUSA - Agurain S/N - 01200 Salvatierra (Alava) España
Tel.: (+34) 945 18 00 00 Fax : (+34) 945 30 01 53 e-mail: ventas@atusa.es
www.atusa.es

