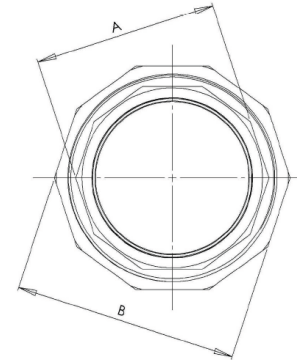
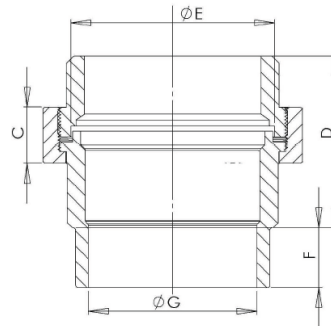

Fig. 331

MANCHON UNION A JOINT PLAT M/F
UNION FLAT SEAT M/F

ISO 4144

INFORMATION TECHNIQUE - TECHNICAL INFORMATION

DN	CODE	DIMENSIONS - DIMENSIONS							Poids approx. Weight approx. (g)
		A (mm)	B (mm)	C (mm)	D (mm)	E (mm)	F (mm)	G (mm)	
1/4"	I3316001	17,0	31,0	13,8	34,5	17,5	14,0	8,5	83
3/8"	I3316002	21,5	33,5	15,0	37,0	20,5	14,0	11,5	90
1/2"	I3316003	24,0	37,0	16,5	40,6	25,0	17,5	15,0	143
3/4"	I3316004	30,3	46,0	18,0	43,5	32,0	20,0	20,0	228
1"	I3316005	37,0	52,3	20,4	51,5	38,0	21,0	26,0	304
1 1/4"	I3316006	46,5	65,0	22,5	54,5	48,0	23,5	34,5	460
1 1/2"	I3316007	53,0	69,0	24,0	58,0	54,5	21,0	40,0	587
2"	I3316008	64,0	80,6	27,0	66,0	68,0	24,5	50,7	856
2 1/2"	I3316009	82,0	108,0	29,5	75,3	85,0	32,0	64,0	1.545
3"	I331600A	95,0	120,5	31,0	83,3	96,0	35,0	78,0	2.071
4"	I331600C	121,0	148,5	34,0	110,3	123,0	36,0	101,0	3.386

CARACTERISTIQUES DE BASE

- Fabriqué en acier inoxydable austénitique AISI 316 avec traitement thermique standard.
- Méthode de fabrication: Fusion.
- Dimensions selon norme ISO 4144.
- Filets selon norme NF EN 10226-1 / ISO 7-1 (type R-Rp).
- Température de travail: de -20 à 220 °C.
- Pression de travail: PN 20.
- Joint d'étanchéité PTFE.

DOMAINES D'APPLICATION

- Fluides, air, vapeur, huiles et gaz.

BASIC FEATURES

- Made of austenitic stainless steel AISI 316 with standard heat treatment.
- Production method: Fusion.
- Dimensions according to ISO 4144 standard.
- Threads according to EN 10226-1 / ISO 7-1 (type R-Rp).
- Working temperature range: -20 to 220 °C.
- Maximal working pressure: PN 20.
- PTFE Tightness joint.

GENERAL APPLICATIONS

- Water, air, steam, oil and gas.

Note : En raison de l'évolution constante de nos produits, ces spécifications peuvent être modifiées sans préavis.

Note : Due to the continuous development of our products, specifications may be changed without notification at any time.

Rev.1-07.19



Polígono Industrial ATUSA - Agurain S/N - 01200 Salvatierra (Alava) España
 Tel.: (+34) 945 18 00 00 Fax : (+34) 945 30 01 53 e-mail: ventas@atusa.es
www.atusa.es

