

Fig. 92

# ACCESSOIRES INOX FILETES - COUDE 90° M/F

## THREADED STAINLESS STEEL FITTING - ELBOW 90° M/F



ISO 4144

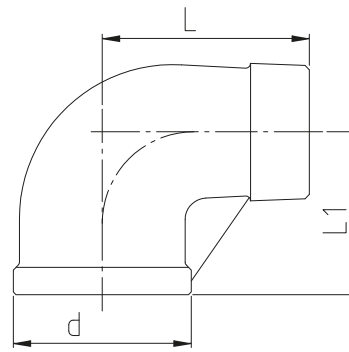

### INFORMATION TECHNIQUE - TECHNICAL INFORMATION

DN	CODE	DIMENSIONS - DIMENSIONS			Poids approx. Weight aprox. (kg)
		L1 (mm)	L (mm)	d (mm)	
1/8"	I0926000	17	26	14,6	0,020
1/4"	I0926001	19	28	17,5	0,030
3/8"	I0926002	23	32	22,0	0,045
1/2"	I0926003	27	36	27,0	0,075
3/4"	I0926004	32	42	32,0	0,105
1"	I0926005	38	53	39,5	0,180
1 1/4"	I0926006	45	59	49,0	0,270
1 1/2"	I0926007	48	64	55,0	0,360
2"	I0926008	57	72	67,0	0,600
2 1/2"	I0926009	69	87	84,0	0,960
3"	I092600A	78	102	98,5	1,540
4"	I092600C	97	125	123,5	2,640

### CARACTERISTIQUES DE BASE

- Fabriqué en acier inoxydable austénitique AISI 316 avec traitement thermique standard.
- Méthode de fabrication: Fusion.
- Dimensions selon norme ISO 4144.
- Filets selon norme NF EN 10226-1 / ISO 7-1 (type R-Rp).
- Température de travail: de -20 à 220 °C.
- Pression de travail: PN 20.

### DOMAINES D'APPLICATION

- Fluides, air, vapeur, huiles et gaz.

#### Remarques:

Étant donné la complexité, la variété et le grand nombre de spécifications particulières de chaque installation, conjugués à l'existence de divers facteurs pouvant affecter les conditions de travail et la nature du produit, il incombe à l'utilisateur final d'effectuer les tests nécessaires pour assurer un bon fonctionnement du produit dans chaque domaine d'application.

L'installation du produit doit être effectuée et entretenue conformément aux bonnes pratiques et aux normes en vigueur.

### BASIC FEATURES

- Made of austenitic stainless steel AISI 316 with standard heat treatment.
- Production method: Fusion.
- Dimensions according to ISO 4144 standard.
- Threads according to EN 10226-1 / ISO 7-1 (type R-Rp).
- Working temperature range: -20 to 220 °C.
- Maximal working pressure: PN 20.

### GENERAL APPLICATIONS

- Water, air, steam, oil and gas.

#### Remarks:

Due to the complexity, variety and large number of particular specifications for each installation, along with the existence of diverse factors which can affect the working conditions and nature of the product, it is the responsibility of the end-user to carry out the necessary tests to ensure the proper functioning of the product in any specific application.

Product installation must be carried out and maintained following the good practice codes and/or updated technical standards.

Note : En raison de l'évolution constante de nos produits, ces spécifications peuvent être modifiées sans préavis.

Note : Due to the continuous development of our products, specifications may be changed without notification at any time.

Rev.2-11.20



Polígono Industrial ATUSA - Agurain S/N - 01200 Salvatierra (Alava) España  
 Tel.: (+34) 945 18 00 00 Fax : (+34) 945 30 01 53 e-mail: [ventas@atusagroup.com](mailto:ventas@atusagroup.com)  
[www.atusagroup.com](http://www.atusagroup.com)