

637

# VÁLVULA MARIPOSA TIPO WAFER CON FINAL DE CARRERA (VOLANTE)

## WAFER BUTTERFLY VALVE WITH TAMPER SWITCH (HANDWHEEL)

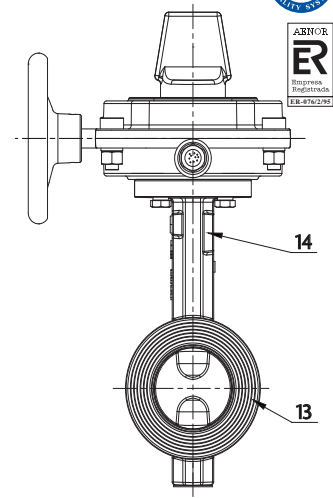
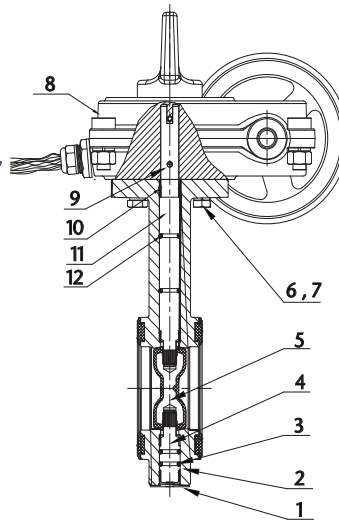

### DESCRIPCIÓN COMPONENTES - COMPONENTS DESCRIPTION

Ítem	Descripción - Description	Material - Material
1	Tapón - Plug	EPDM
2	Cuerpo - Body	Fundición nodular - Ductile Iron EN 1562 (EN-GJS-450-10)
3	O-Rings (2)	NBR
4	Eje inferior - Stub shaft	Acero Inoxidable - Stainless Steel UNS S43100 (SS431)
5	Disco - Disc	Fundición nodular - Ductile Iron EN 1562 (EN-GJS-450-10) + EPDM
6	Tuerca hexagonal - Hexagonal nut	Acero al carbono electrozincado - Carbon steel cinz plated
7	Arandela presión elástica - Grower Spring washer	Acero al carbono - Carbon steel
8	Caja Reductora - Gear box	Fundición nodular - Ductile Iron EN 1562 (EN-GJS-450-10)
9	Pin cilíndrico - Cylindrical pin	AISI 304
10	Bushing	AISI 304 + PTFE
11	Eje - Drive shaft	Acero Inoxidable - Stainless Steel UNS S43100 (SS431)
12	O-Ring	NBR
13	Elastómero - Seat	EPDM
14	Placa - Name plate	Acero Inoxidable - Stainless Steel

### CARACTERÍSTICAS BÁSICAS

- Fabricación según EN 593
- Brida montaje actuador: ISO 5211
- Presión servicio: PN10/16 (150/230 PSI ; 1,0/1,6 MPa)  
Nota: UL aprobado 25 bar / 363 PSI / 2,5 MPa  
FM aprobado 20 bar / 300 PSI / 2,0 MPa
- Temperatura de servicio: 0 - 80 °C
- Acabado: recubrimiento epoxi s/ ANSI-AWWA C550, color rojo.

### APLICACIONES GENERALES

- Servicio aguas, saneamiento, riego, sistemas anti-incendios.

#### Observaciones:

Dada la complejidad, variedad y gran cantidad de especificaciones particulares de cada instalación, en conjunción con la existencia de diversos factores que pueden afectar a las condiciones de trabajo y naturaleza del producto, es responsabilidad del usuario final realizar los ensayos necesarios para garantizar el correcto funcionamiento del producto en cada aplicación concreta.

La instalación del producto deberá realizarse y mantenerse siguiendo códigos de buena práctica y/o estándares existentes.

### BASIC FEATURES

- Production according to EN 593
- Top flange: ISO 5211.
- Working pressure: PN10/16 (150/230 PSI ; 1,0/1,6 MPa)  
Note: UL approval 25 bar / 363 PSI / 2,5 MPa  
FM approval 20 bar / 300 PSI / 2,0 MPa
- Working temperature: 0 - 80 °C.
- Finished red: fusion bonded epoxi coating acc. ANSI-AWWA C550.

### GENERAL APPLICATIONS

- Supply and sanitary water services, irrigation, fire fighting systems.

#### Remarks:

Due to the complexity, variety and large number of particular specifications for each installation, along with the existence of diverse factors which can affect the working conditions and nature of the product, it is the responsibility of the end-user to carry out the necessary tests to ensure the proper functioning of the product in any specific application.

Product installation must be carried out and maintained following the good practice codes and/or updated technical standards.

Rev.0-10.21

1/2



Polígono Industrial ATUSA - Agurain S/N - 01200 Salvatierra (Alava) España  
Tel.: (+34) 945 18 00 00 Fax : (+34) 945 30 01 53 e-mail: [ventas@atusagroup.com](mailto:ventas@atusagroup.com)  
[www.atusagroup.com](http://www.atusagroup.com)



# 637

## VÁLVULA MARIPOSA TIPO WAFER CON FINAL DE CARRERA (VOLANTE) WAFER BUTTERFLY VALVE WITH TAMPER SWITCH (HANDWHEEL)

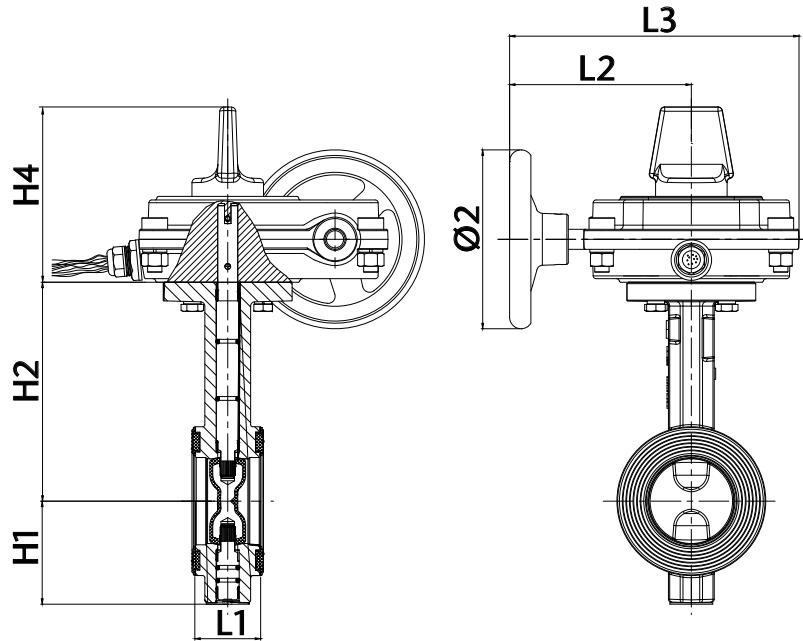

### INFORMACIÓN TÉCNICA - TECHNICAL INFORMATION

Tubo Acero - Steel Pipe			COD.	DIMENSIONES - DIMENSIONS							Brida superior Top flange ISO 5211	Peso aprox. Weight approx. (kg)
DN	NPS	ØD (mm)		Ø2 (mm)	H1 (mm)	H2 (mm)	H4 (mm)	L1 (±2) (mm)	L2 (mm)	L3 (mm)		
50	2"	60,3	6V637208	125	65	140,5	122,5	43	127,0	202,2	F07	8,50
65	2 1/2"	76,1	6V63720B	125	71	153,0	122,5	46	127,0	202,2	F07	8,86
80	3"	88,9	6V63720A	125	81	157,5	122,5	46	127,0	202,2	F07	9,47
100	4"	114,3	6V63720C	125	95	176,0	122,5	52	127,0	202,2	F07	10,87
125	5"	139,7	6V63720H	125	111	191,0	122,5	56	127,0	202,2	F07	12,61
150	6"	168,3	6V63720E	225	133	202,5	122,5	56	139,5	215,0	F07	16,33
200	8"	219,1	6V63720M	225	164	243,5	122,5	60	198,5	274,0	F10	21,74
250	10"	273,0	6V63720N	225	196	273,0	122,5	68	198,5	274,0	F10	30,79
300	12"	323,9	6V63720Q	225	226	311,0	132,0	78	202,0	293,5	F10	44,56

### Diagrama Cableado / Wiring Diagram

16A 1/2 HP 125/250 VAC

Switch 1

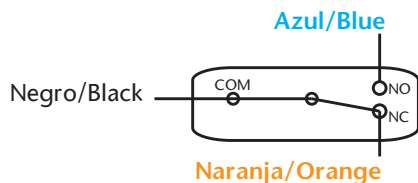

Switch 2

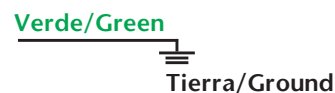
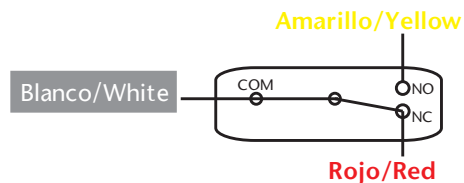

**NO:** Normally Open / Normalmente Abierto  
**NC:** Normally Closed / Normalmente Cerrado

**AVISO Importante:** no modificar ni eliminar ningún componente de la instalación sin haber primero despresurizado y drenado completamente el circuito, de lo contrario pueden resultar graves daños personales y/o materiales.

**Important NOTICE:** never remove or modify any piping component without first de-pressurizing and draining completely the installation. Failure to do it could result in serious personal injury and/or economical losses.

Nota : Debido al constante desarrollo de nuestros productos, el diseño y los datos suministrados pueden ser alterados sin previo aviso.

Note : Due to the continuous development of our products, the design and information given, may be changed without notification at any time.

Rev.0-10.21

2/2



Polígono Industrial ATUSA - Agurain S/N - 01200 Salvatierra (Alava) España  
Tel.: (+34) 945 18 00 00 Fax : (+34) 945 30 01 53 e-mail: [ventas@atusagroup.com](mailto:ventas@atusagroup.com)  
[www.atusagroup.com](http://www.atusagroup.com)

